

Sanitary Components

Technical document 076-02

Inlet valves for flushing cisterns

Technical document 076-02 rev. 10
01/09/2018

The CSTB (Centre Scientifique et Technique du Bâtiment), a public establishment supporting innovation in construction, has four key activities: research, expertise and the assessment and dissemination of knowledge, organised to meet the challenges of ecological and energy transition in the construction sector. Its field of competence covers construction materials, buildings and their integration into districts and towns.

With over 900 employees, its subsidiaries and networks of national, European and international partners, the CSTB group works for all the stakeholders in the construction sector to push forward the quality and safety of buildings.

All reproduction or representation, complete or partial, by whatever means, of the pages published in this technical document and executed without the authorisation of the CSTB is illegal and constitutes a counterfeit. The only authorised exceptions are reproductions strictly reserved for the use of the typist and not for the purpose of any collective use; or analyses and short quotations required due to the scientific or information nature of the work in which they figure (article L.122-5 of the Intellectual Property Code). This document has been drawn up under the initiative and direction of the CSTB, which has brought together the opinions of all interested parties.

© CSTB

Modification history

Revision No.	Date	Modifications
10	01/09/2018	Update to the document introduction and reference.

Table of contents

1 APPLICATION RULES OF STANDARD NF EN 14124 AND ADDENDUM TO SPECIFICATIONS.....	5
Purpose	5
1.1 Choice of materials	8
1.2 Immersed connectors.....	8
1.3 Supply network end connection	8
1.4 Non-return safety	10
1.5 Air intake dimensions.....	10
1.6 Static pressure test	11
1.7 Reopening the filling valve	12
1.8 Water hammer	12
1.9 Endurance.....	13
1.10 Marking and presentation for delivery.....	13
1.11 Intermediate connection device	13
1.12 Resistance to stresses from alternating pressures.....	15
2. QUALITY REQUIREMENTS OF THE MANUFACTURER'S PRODUCTION FOR THE INLET VALVES FOR THE FLUSHING CISTERN.....	17
2.1 Nature and frequency of the quality assurance operations	17
3. PROCEDURES FOR THE QUALITY ASSURANCE OPERATIONS CARRIED OUT BY CSTB	19
3.1 Types of products.....	19
3.2 Nature of the inspections and tests.....	19
3.3 Sampling.....	20

1 APPLICATION RULES OF STANDARD NF EN 14124 AND ADDENDUM TO SPECIFICATIONS

Purpose

The following table contains the list of requirements set down in standard NF EN 14124 and identifies the clauses that have been modified and/or extended and are presented in this document, and are applicable to all tapware to which this standard is applicable.

Table 1: List of points to be verified

Specifications clause in Standard NF EN 14124	Requirements	Clauses of this document	
1	Scope	/	/
2	Normative references	/	/
3	Terms and definitions	/	/
4	Materials	clause completed	1.1
5	Design and manufacture	/	
5.1	Composition of the inlet valve	/	
5.2	Connection to the supply network	clause completed	1.2
5.3	Adjustment of the water level	/	
5.4	Dimensions of the threaded end connections	clause completed	1.3.1
6	Mechanical and hydraulic characteristics	clause added	1.3.2.2
6.1	Threaded end connections	/	
6.1.1	General	clause completed	1.3.2.1
6.1.2	Tensile strength	/	
6.1.3	Resistance to tightening torque	/	
6.2	Backflow prevention	/	
6.2.1	General	clause completed	1.4.1
6.2.2	Dimension of the air inlet	clause added	1.5
6.2.3	Efficiency of the air inlet	/	
6.3	Leaktightness	/	
6.3.1	Leaktightness under static pressure	/	
6.3.2	Leaktightness under dynamic pressure	/	
6.4	Flow rate and filling time	/	
6.5	Reopening of the inlet valve	clause completed	1.7
6.6	Water hammer	/	
6.7	Resistance to pressure	/	

Specifications clause in Standard NF EN 14124	Requirements	Clauses of this document	
6.8	Endurance	/	
7	Tests	/	
7.1	General	/	
7.2	End connections	clause completed	1.3
7.2.1	Tensile test and torque test apparatus	/	
7.2.2	Tensile test operating method	/	
7.2.3	Torque test operating method	/	
7.3	Backflow prevention	/	
7.3.1	Test apparatus	/	
7.3.2	Operating method	clause completed	1.4.2
7.4	Leaktightness	/	
7.4.1	Test apparatus	/	
7.4.2	Static pressure test method	clause completed	1.6
7.4.3	Dynamic pressure test method	/	
7.5	Inlet flow rate	/	
7.5.1	Test apparatus	/	
7.5.2	Test method	/	
7.6	Reopening of the inlet valve	/	
7.6.1	Test apparatus	/	
7.6.2	Test method	/	
7.7	Water hammer	/	
7.7.1	Test apparatus	clause completed	1.8
7.7.2	Test method	clause completed	
7.8	Resistance to pressure	/	
7.8.1	Test apparatus	/	
7.8.2	Test method	/	
7.9	Endurance	/	
7.9.1	Test apparatus	/	
7.9.2	Test method	clause completed	1.9

Specifications clause in Standard NF EN 14124	Requirements	Clauses of this document	
8	Acoustic characteristics	/	
9	Marking	clause completed	1.10
10	Designation	/	
Appendix A	Diagram	/	
	Intermediate connection device	clause added	1.11.1
	Resistance to alternating pressure loads	clause added	1.12

1.1 Choice of materials

Clause 4 in standard NF EN 14124 is extended by the following requirements:

1.1.3.1 End connection:

The end connection of the filling valve shall be made from one of the alloys defined below.

Cu Zn39 Pb3	CW 614 N	NF EN 12164
Cu Zn40 Pb2	CW 617 N	NF EN 12164

If other metallic materials are used, the choice of these materials shall be technically justified.

1.2 Immersed connectors

Clause 5.2 in Standard NF EN 14124.

Adjustable valves for bottom feed systems shall not be accepted for the NF mark.

According to standard NF EN 13078 clause 7.2 paragraph 4, “**Adjustable or dismantle able** joints to submerged supply pipes to the inlet device are not permitted below the critical level.”

1.3 Supply network end connection

1.3.1 Tightening nut

Clause 5.4 in Standard NF EN 14124.

The backnut for the tapware, the end connection of which has a threading 3/8 or 1/2 is:

- Either a cast, press-formed or lathe turned nut, with:
 - threading 3/8 or 1/2, ISO 228-1
 - tap height: 5 mm minimum
 - gripping contact surface height: 5 mm minimum
- or a nut of stamp formed steel sheet, efficiently protected against oxidation with a gripping contact surface height equal to or greater than 5 mm

If the tightening nut is metal, additional protection washers of an appropriate material (plastic for example) are necessary.

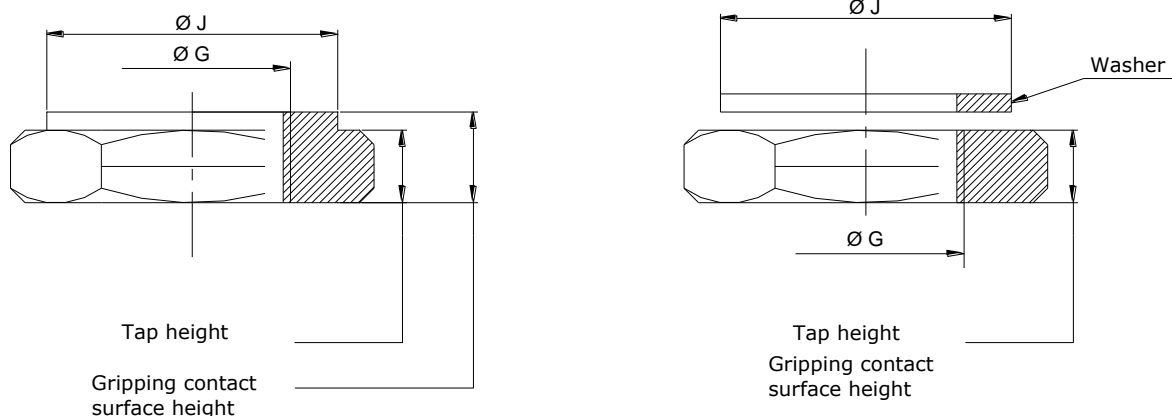

Figure 1

1.3.2 Bimaterial end connections

1.3.2.1 Threaded end connections

Article 6.1.1 of standard NF EN 14124 is completed by the following requirements:

Under the NF Sanitary Components mark, connections made only with plastic are not authorised.

For bimaterial end connections, the effective thickness of the brass part (measured at the thread root) shall be equal to or greater than 1 mm.

1.3.2.2 Bending strength

Article 6 of standard NF EN 14124 is completed by the following requirements:

Required characteristics

Under the conditions of the test defined below, during one minute apply a force F of 120 N.

This shall produce neither permanent deformation nor break.

Methodology

The test methodology is to make sure that a force considered as normal, applied on the valve's end connection, mounted on a support, has no negative effect on that end connection's strength.

Test method

- Mount the valve on the device shown on Figure 2 of the Standard.
 - Block the valve on the square using its tightening nut and adapt a threaded ring onto the extremity of the end connection
 - At 5 mm from the extremity, apply the force 120 N and maintain it during the specified time.
- During and at the end of the test, record all possible deformations or breaks.

1.4 Backflow prevention

1.4.1 Supply device

Clause 6.2.1 in standard NF EN 14124 is extended by the following requirement:

A valve supply device that has an outlet orifice designed to operate when immersed, shall be provided with an air inlet open at rest.

The air inlet is open when the tank is full.

1.4.2 Procedure

1.5 Air inlet dimensions

The following diagram helps to interpret the requirements of clause 6.2.2 in standard NF EN 14124.

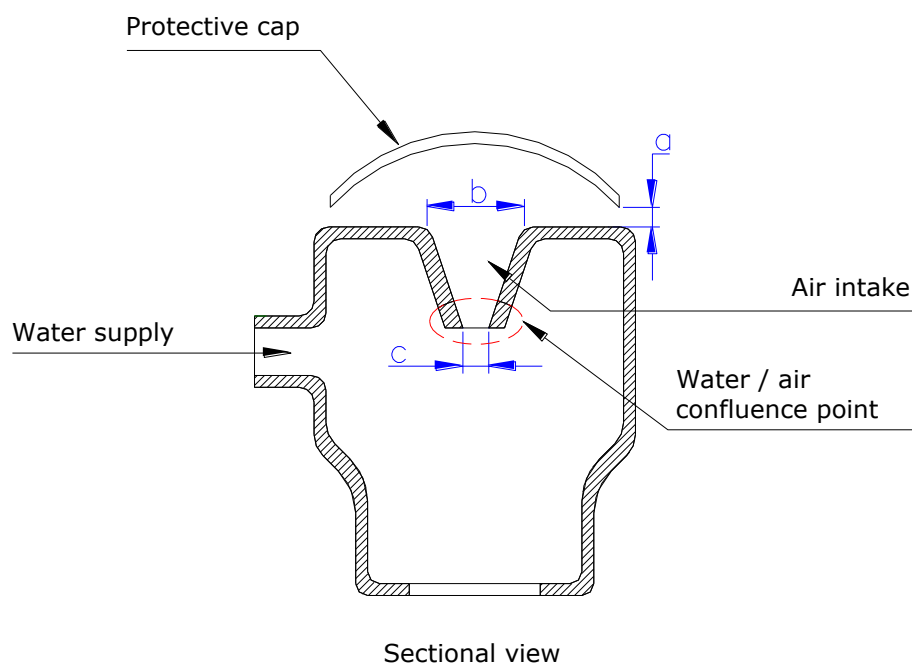

$$a \geq 4 \text{ mm}$$

$$b \geq 4 \text{ mm}$$

$$c \geq 4 \text{ mm}$$

Figure 2: Air intakes dimensions

1.6 Static pressure test

Clause 7.4.2 in standard NF EN 14124 is extended by the following requirement:

The leak tightness of the valve shall be demonstrated by recording the level in the tank.

It shall be checked that the valve is leaktight before the end of each plateau, for example by verifying that the gradient of the curve is zero (figure 3).

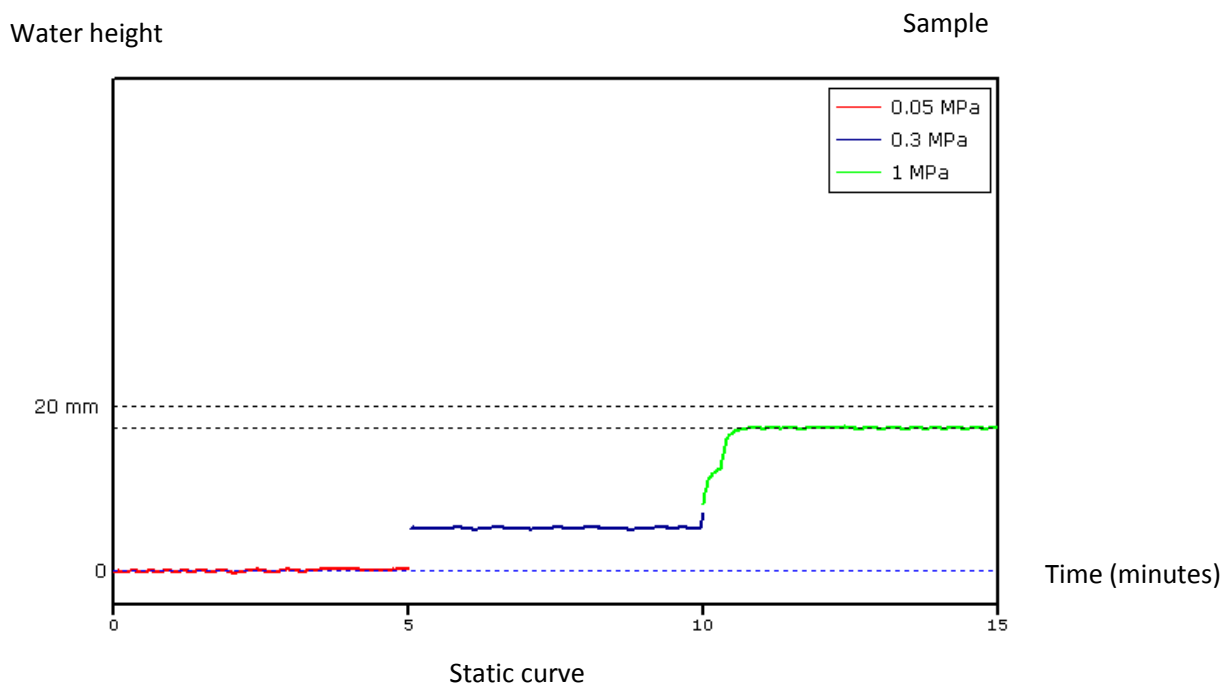

Figure 3 (satisfactory curve with stable plateau)

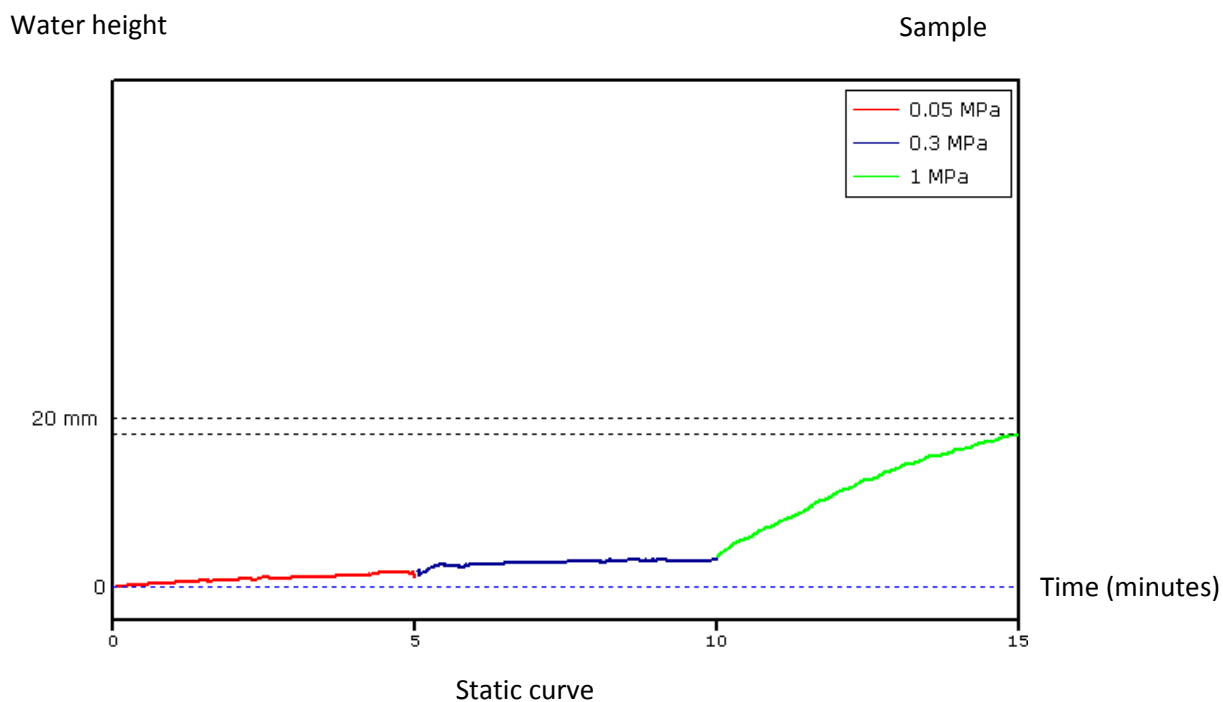

Figure 4 (unsatisfactory curve)

1.7 Reopening the inlet valve

Clause 6.5 in standard NF EN 14124 is modified by the following requirement:

Reopening shall begin before the water level has dropped by 65 mm and not afterwards.

1.8 Water hammer

1.8.1 Test equipment

Clause 7.7.1 in standard NF EN 14124 is modified as follows:

A piezoelectric pressure sensor with a natural frequency > 5 kHz shall be used.

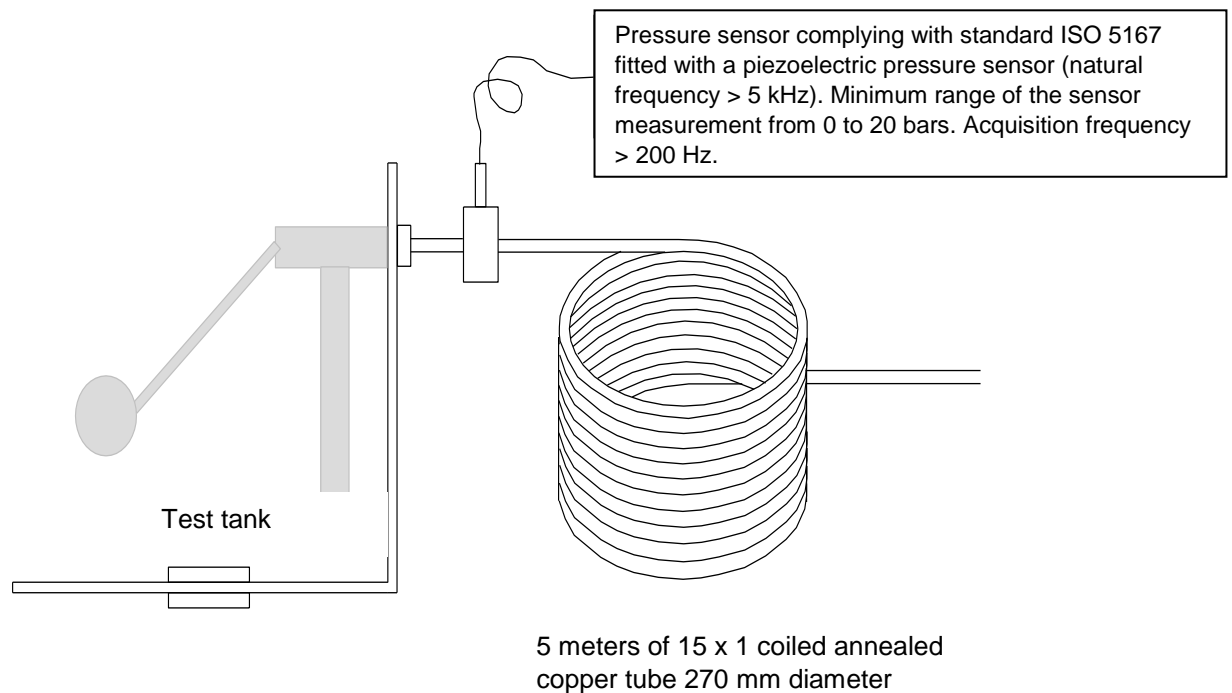

Figure 5: Device to measure water hammer

1.8.2 Procedure

Clause 7.7.2 in standard NF EN 14124 is extended and modified as follows:

- The inlet valve shall be supplied under static pressure.
- The test is done on three samples of the same product. Three tests are repeated on each sample.
- For each sample, the « average overpressure » is calculated from three results obtained. The overpressure is equal to the difference between the maximum pressure (water hammer) and the static pressure.
- The selected value will be the highest average value.

1.9 Endurance

Clause 7.9.2 in standard NF EN 14124 is extended by the following requirement:

If necessary, the compatibility test with network disinfection products shall be carried out before the endurance cycles. Proceed as follows:

- Install the valve in a tank or an off-the-shelf cistern.
- Supply the valve with treated water at a pressure of between 2 bars and 5 bars.
- Keep the valve in the closed position at the test pressure for a determined duration defined in clause 3 in technical document 1 of certification rules NF076.

The procedure defined in clause 7.9.2 in standard NF EN 14124 is extended by the following requirements:

- The valve closing time was initially (15 ± 5) s, and is fixed at (5 ± 1) s.
- The number of cycles (each cycle including opening and closing the valve) is modified to:
 - 200 000 for admissions, extensions
 - 50 000 for review inspections and corrective actions.

1.10 Marking and presentation for delivery

Clause 9 in standard NF EN 14124 is extended by the following requirement:

If the valve is not fitted with an air gap (in other words if it is fitted with an immersed outlet pipe), a mark shall be provided to locate the maximum level for adjusting the overflow.

Valves shall be stored and delivered with their threaded end connections protected (for example with a connection nut, etc.).

1.11 Intermediate connection device

1.11.1 Device incorporated in the valve

General

This Article applies to special devices enabling the connection between the end connection and the inlet valve.

The purpose of these specifications is to establish:

- The characteristics of suitability for the application of special devices enabling the connection between the end connection and the inlet valve.
- The test method making it possible to verify these characteristics.
- Marking and presentation.

For the end connection, the specifications of Standard NF EN 14124 and of this document apply.

These tests are also applicable to so-called « special » valves, in other words valves that will be fitted on plastic cisterns. Tests shall then be made with the hose.

These tests do not concern devices covered by a quality mark (CSTBat or QB, NF).

Definition

Incorporate devices for supplying the flushing valve located between the end connection and the inlet valve.

These supply devices are an integral part of the valve and cannot be used alone.

The devices are as follows:

- At the inlet, a threaded end connection in compliance with the requirements of Standard NF EN 14124 and of this document,
- At the outlet, the type of connection is left to the manufacturer's initiative.

Tests performed

The other tests specified as part of the inlet valve's certification are to be carried out on the complete product.

- **End connections to the supply network:**

The inlet end connection (end connection to the supply network) of the pipe shall comply with the specifications in Standard NF EN 14-124 and with the technical specifications of this document.

- **Hygiene and physico-chemical characteristics:**

The device shall comply with the specifications of Standard NF EN 14124 and with the technical specifications of this document.

- **Pressure resistance characteristics:**

Comply with Standard NF EN ISO 1167-1.

The test consists of maintaining the device under a static pressure of water. This test is carried out at 20°C at a pressure equal to three times the working pressure (that is, 30 bars).

The minimal required resistance time is 1 hour.

- **Instantaneous bursting test:**

The test consists of raising the pressure regularly until failure according to Standard NF T 54-091 so as to obtain bursting at from 60 to 70 seconds, with the test specimen dipped in a tank of water at 60°C.

The bursting shall be observed at a minimal pressure of 30 bars.

- **Tensile strength:**

In compliance with Standards NF EN ISO 6259-1 and NF EN ISO 6259-2.

The test is carried out on the device and on the connections. The test is carried out with a separation speed of the jaws of 100 mm/min. This test is carried out at 20°C on new samples.

The break shall be observed for a force of at least 300 N.

- **Resistance tests to alternating pressures:**

The test consists of applying to the device a pressure variation of 1 to 3 times the Nominal Pressure (working pressure, 10 bars) at a frequency of 1 Hertz.

This test is carried out at ambient temperature.

The signal has a rectangular form in accordance with Standard NF T 54-094.

Neither bursting nor leakage shall be observed before 250 000 cycles.

Marking:

The device shall carry:

- Mark holder's name,
- Material type,
- Or a codification declared to CSTB.

1.11.2 Independent hose

While awaiting the issue of a European Standard, the connection hoses used shall hold a Technical Assessment.

For this usage, they shall also satisfy the corrosion test according to the specifications of Standard ISO 9227.

The Technical Assessment number as well as the CSTBat or QB identification mark shall appear on these products.

1.12 Resistance to stresses from alternating pressures

Purpose

The valves installed in a sanitary installation are subject to considerable pressure variation due to the closures of other devices installed – solenoid valves of washing machines, mixing taps, check valves, etc.

The test below ensures their resistance to these stresses.

General description of the test

The test consists of applying, during 10 000 cycles, a pressure variation of 1 to 3 times the nominal pressure to the valve tap that is kept closed.

Apparatus

The apparatus comprises a pressure generator capable of generating a variable pressure that can oscillate with a constant frequency between a low limit and a high limit, defining a constant amplitude. The diagram of that variation shows a substantially rectangular signal form (see Figure 6).

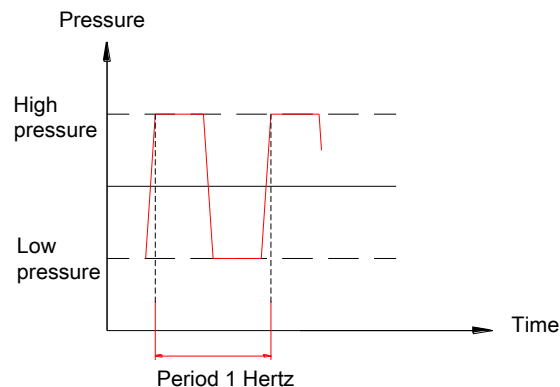

Figure 6: Alternating pressures

- The time necessary to go from the low pressure to the high pressure and back shall be as short as possible and, in any case, less than one tenth of the period (cycle);
- The values of the low and high pressures shall be obtained and monitored to within $\pm 1\%$ of the desired values;
- To monitor the form of the signal representing the pressure variation, it is necessary to associate, with the generator, a device to verify the evolution of the pressure in the test specimen (pressure sensor with low inertia and graphic recorder or oscilloscope).

Test

The valve, mounted in a cistern, is closed under a water pressure, then maintained closed artificially.

Carry out 10 000 cycles of alternating pressures,

- Low pressure 10 bars (nominal pressure);
- High pressure of 30 bars.

Specifications

Following the test, no break or permanent deformation shall be detected. Any leaks during the test are not to be taken into account.

2. QUALITY REQUIREMENTS OF THE MANUFACTURER'S PRODUCTION FOR THE INLET VALVES FOR THE FLUSHING CISTERN

2.1 Nature and frequency of the quality assurance operations

2.1.1 Verification during production

The manufacturer shall make sure that the characteristics described in product Standard NF EN 14124 and in Part 1 of this document are complied with. However, procedures and equipment, different from those described in the standards may be used.

The quality assurance operations on characteristics during production as well as their frequencies are specified in the Table below.

Quality assurance operations during production

Characteristics checked	Check frequency
Marking	Quality documentation
Conformation and packaging	Quality documentation
Standardised dimensions	Quality documentation
Hygiene (Dimensions)	Quality documentation
Procurement of materials and components	Identification of the material for each batch at each delivery or compliance certificate from the supplier and/or Quality assurance operation
Leaktightness	100% of the pieces
Hydraulic characteristics (Presence of flow)	100% of the pieces

2.1.2 Quality assurance operations on the finished products

The procedures for the inspections and tests carried out as part of finished product quality assurance operations in the factory's laboratory, and the test equipment used, shall comply with the specifications of Standard NF EN 14124 and of Part 1 of this document.

The products to be checked are sampled at the end of the assembly lines (after packaging) or as they come into the warehouse.

The types of quality assurance operations on finished products as well as their sampling are defined in the Table below.

Quality assurance operations on finished products

Tests	Sampling: Sampling plans approved by CSTB
Marking (§1.10 of DT 076-02 and § 9 of Standard NF EN 14124)	yes
Presentation (§1.10 of DT 076-02)	yes
Bimaterial end connection (§1.3.2 of DT 076-02)	yes
Dimensional characteristics (§ 1.3.1 of DT 076-02 and § 5.4 of Standard NF EN 14124), (§1.5 of DT 076-02)	yes
Static leaktightness characteristics (§ 1.6 of DT 076-02 and § 7.4.2 of Standard NF EN 14124)	yes
Dynamic leaktightness characteristics (§ 7.4.3 of Standard NF EN 14124)	yes
Hydraulic characteristics (§ 7.5 of Standard NF EN 14124)	yes
Pressure resistance characteristics (§ 7.8 of Standard NF EN 14124)	yes
Some tests may not be necessary for ISO 9001 certified manufacturing sites. In this case, the holder shall prove compliance with the specifications through design control and the auditor shall verify the design to assure control over the system.	

3. PROCEDURES FOR THE QUALITY ASSURANCE OPERATIONS CARRIED OUT BY CSTB

3.1 Types of products

A product is designated by:

4. its size,
5. its assembly method,
6. its adjustment possibilities,
7. its acoustic group,
8. the reference to the standard.

A product can be explicated:

9. as a system defining the hydraulic part,
10. as a variant, explication of a single system.

3.2 Nature of the inspections and tests

The inspections and tests are carried out in compliance with the instructions of Standard NF EN 14124 and with the added specifications of this document.

Test No.	Nature of the tests
1	Verification of the dimensional characteristics
2	Verification of the efficiency of the air inlet
4	Checking the leaktightness: static pressure test
5	Checking the leaktightness: dynamic pressure test
6	Hydraulic characteristics
7	Pressure resistance characteristics
8	Mechanical endurance
9	Bending strength, tensile strength and resistance to tightening torque
10	Acoustic characteristics
11	Water hammer
12	Resistance to stresses from alternating pressures
13	Marking
14	Pressure resistance on incorporated feed pipe
15	Tensile stress on incorporated feed pipe
16	Resistance to alternating pressures on incorporated feed pipe
17 (*)	Checking corrosion resistance
18 (*)	Checking the plating's adhesive strength
19	Compatibility with the supply network's disinfection products

So as not to multiply the tests on components common to several products (hydraulic system, type of threading, type of supply or feed method) correlations can be applied.

(*): These tests concern the Nickel/Chrome plated components that come with the valve.

3.3 Sampling

3.3.1 Case of admission

The tests are carried out according to the procedures described below on samples taken during the admission audit.

Tests 1 to 13 and 17 to 19 are carried out,
Tests 14 to 16 are carried out in the case of hose incorporated with the valve.
For the marking (characteristic 13), the manufacturer shall present an implementation plan.

3.3.2 Case of follow-up

The tests are carried out according to the procedures described below on the samples taken during the follow-up audit.

Test No.	Nature of the quality operations on the products and samplings
19	At each change of material or process
1, 2, 4, 5, 6, 8, 13, 19	On all the models of products sampled
7, 9, 11, 12, 17, 18	Every two years, on one model of the products sampled
10*	Every five years, 3 products per connection method for a single system
14, 15,16	Once per model per year
*: acoustic tests	

3.3.3 Case of additional admission (new products) or extension (modified products)

After CSTB's agreement, and depending on the modifications, the manufacturer sends the necessary samples for carrying out the tests.